

# POWERTRACK



DESIGN YOUR OWN  
PROTOTYPE ONLINE



CANopen  
J1939



## FLEXIBLE - SMART - RUGGED

The **PowerTrack** keypad and its rotary encoder were both designed by Blink Marine as a natural evolution of the Powerkey 1000, from which it has inherited the same attractive and compact visual design.

Together with the six quick-pick keys, the addition of a rotary pushbutton knob makes it possible to manage complex scroll functions on the display, and can interface with onboard systems thanks to CANbus protocols. PowerTrack boasts numerous personalization options, thanks in part to the flexible management of multicolor LEDs.

### SOFTWARE FEATURES

**CAN keypad addresses** - You are able to assign any valid CAN address to the keypad.

**CANopen communication protocol** - We have released a new version of our CANopen that is fully compliant with Device Profile 301d. Configurable baud rate and custom CAN message.

**J1939 Address Claim Transmission** - Keypads no longer have to be pre-programmed to a specific address. This enables customers that work in applications in the field without access to a GUI to use any replacement keypad on-hand. The keypad can be configured to automatically announce its address and accept a new address assignment as appropriate.

**Smart led management** - The intensity of the LEDs can be adjusted, whilst any LED indicator - whether fixed or blinking - can be personalized according to color preference. Backlighting for the keypad is also adjustable.

**Concave keys** - The ergonomic design simplifies touch navigation of the quick-pick keys.

**Event Status transmission** - The keypad can send messages to the BUS indicating a button press event or a button release event has occurred. This confirmation allows digital systems to have the same input acknowledgements as that of the latching positions of a mechanical switch.

**Periodic status transmission** - The keypad can be configured to send messages to the CANopen, on a predetermined frequency. This frequency can be set as low as every 10 milliseconds. This feature can be used to monitor the continuity of the system and is also helpful in troubleshooting a fault.

**Periodic heartbeat** - The keypad sends a continuous broadcast of messages to indicate it is still functioning correctly. The frequency of these messages can be adjusted as needed.

### HARDWARE FEATURES

**UV Protected** - UVB 400 hours: Keypad is highly resistant to deterioration caused by exposure to sunlight.

**Splashproof** - PowerTrack is resistant to impacts generated by water spray and other potentially damaging elements like dust, sand and mud.

**Independent KEY** - The device is able to support any multiple pressure key combination.

**An ergonomic knob** - This controller was designed to guarantee a comfortable grip in any given situation thanks to a rubber insert that wraps all the way around the knob.

**Encoder with pushbutton** - Use of the knob is both comfortable and immediate. For example, the knob allows its user to manage scroll & select operations without letting go of the handle.

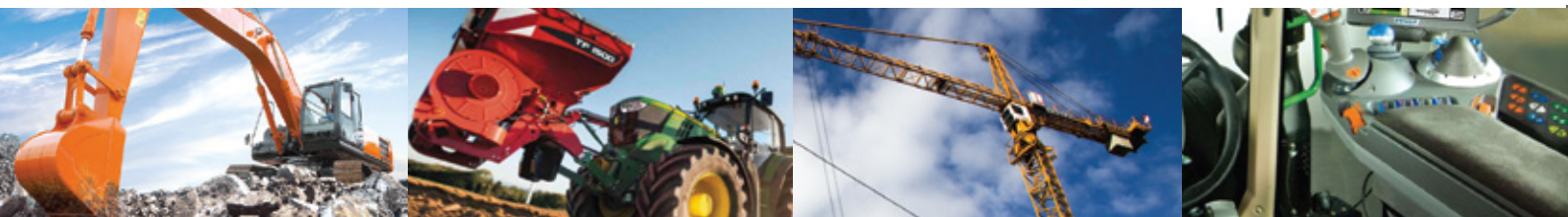

## STANDARD FEATURES

- Custom laser etched icons
- High intensity led status indicators
- Multicolor LED Backlight
- CANopen compliant
- Event status transmission
- Periodic status transmission
- Green/red LED indicators
- Compact design
- Vertical or horizontal mount
- Protected from inverted polarity
- Encoder with pushbutton
- Periodic Heartbeat
- LED acknowledgement
- CANopen and J1939 Communication

## OPTIONAL FEATURES

- RS485 Communication (MOQ 100 pcs.)

## SPECIFICATIONS FOR STANDARD KEYPADS

### ELECTRICAL

Supply Voltage	12-24Vdc Nominal (8-32VDC)
Standby Current	<50 mA
Communication BUS	CANopen, J1939
MTBF	95049 hours (in accordance with MIL-HDBK-217 - operating environment Ground Mobile)

### MECHANICAL

Connector	Deutsch DT04-4P
Switch Life	3 million operation minimum
Encoder pushbutton life:	1 million operations minimum
Encoder rotation life:	100.000 cycles minimum
Mounting Studs	#10-32 Steel
Keypad	Silicone rubber with polyurethane hardcoat
PC Board	1,6mm thick, Nema Grade FR-4, double clad with 1oz copper
Operating Temperature	-40°C to +70°C
Storage Temperature	-40°C to +85°C
UV Protection	UVB 400 hours
Salt Spray	Per ASTM B117
Chemical Resistance	Deet, Engine Cleaner, Isopropyl Alcohol, Suntan Lotion, Multi-Purpose Cleaner, Orange Citrus Cleaner
Ingress protection Rating	IP54
Weight	180 gr

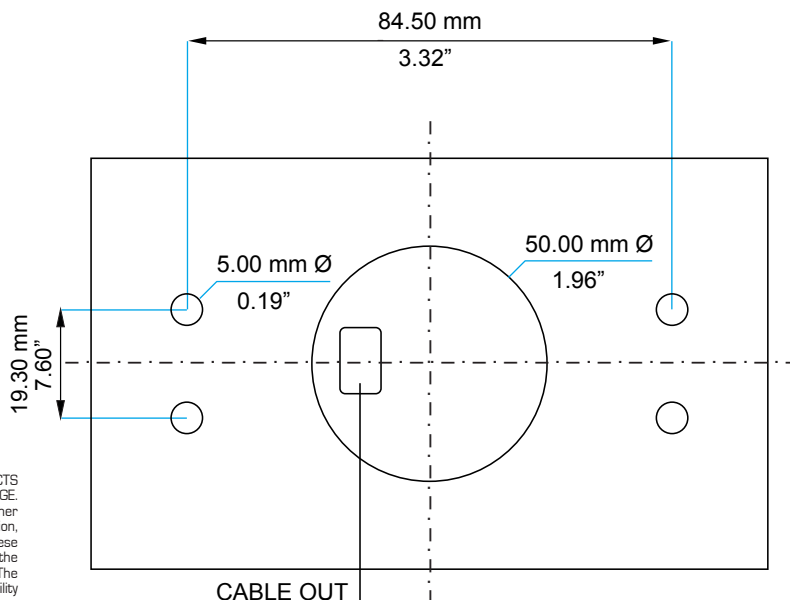
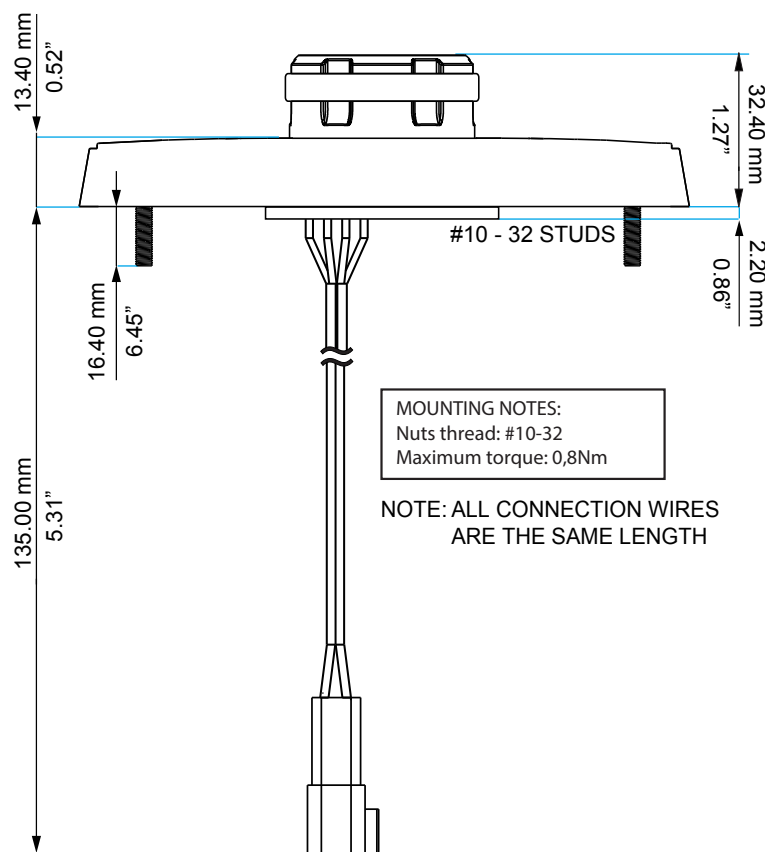
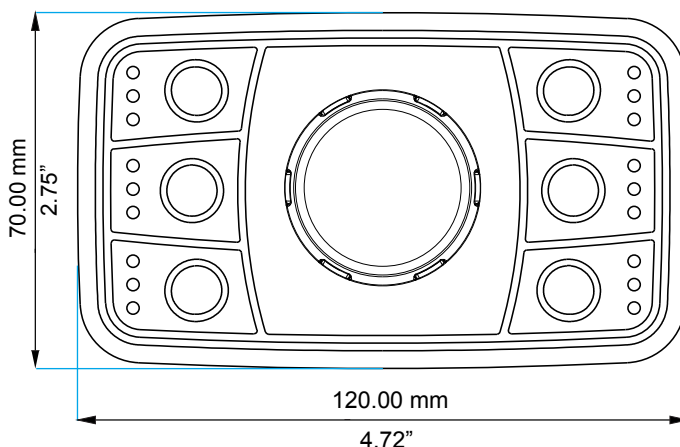

**blink**  
MARINE

**Blink S.r.l.**

Via Montefeltro, 6 - 20156 Milano - Italy

Tel. +39 02 3088583 - Fax +39 02 33406697

[www.blinkmarine.com](http://www.blinkmarine.com) - [info@blinkgroup.com](mailto:info@blinkgroup.com)

!WARNING! IMPROPER SELECTION, IMPROPER USE AND/OR FAILURE OF THE BLINK SYSTEMS PRODUCTS DESCRIBED HEREIN OR RELATED ITEMS CAN CAUSE DEATH, PERSONAL INJURY AND PROPERTY DAMAGE. This document and other information from Blink, provide product and/or system options for further investigation by users having technical expertise. It is important to analyze all aspects of the application, including consequences of any failure. Due to the variety of operating conditions and applications for these product(s), the manufacturer of the application is solely responsible for marking the final selection of the product(s) and assuring that all performance, safety and warning requirements of the application are met. The products described herein, including without limitation, product features, specifications, designs, availability and pricing, are subject to change by Blink at any time without notice.