

AEV250 Series DC Contactor Specification 500 Amp/900 vdc



Application

AEV250 Series is used for charging (pile) station, battery power supply, DC power control, circuit protection and other electric vehicle power switch controls. Also it could be widely used in uninterruptible power supply and other electronic control systems.

Features

HIGH CURRENT AND HIGH VOLTAGE

Contact chamber is filed with inert gas to minimize arcing, up to 900VDC load is available.

COMPACT STRUCTURE, LOW NOISE

Contact design yields reduced unit size, low noise while carrying or switching currents.

COIL ECONOMIZER

Built-in coil economizer – only 1.7W hold power @12VDC and it limits back EMF to 0V.

HIGH SAFETY

There is no arc leakage due to tight sealing.

HIGH RELIABLE CONTACT

Stable contact resistance no matter how harsh environment with sealed contacts.

NO SPECIAL REQUIREMENT FOR MOUNTING

Light weight actuator is less impacted by gravity with no special mounting orientation requirements.

VARIOUS APPLICATION

Application includes battery switch and standby equipment, DC power control, circuit protection, etc.

COMPLY WITH EU ROHS DIRECTIVE (2011/65/EU)



Nomenclature

Example AEV250 – M AN

Series code:
"AEV250" = AEV250 Series

Coil Voltage Code::
"M" = 12 - 24 VDC
"F" = 72 VDC
"G" = 48 - 72 VDC

Options (applied in this order):
Blank = Std. Options (Bottom Mount, Without Aux. Contact & Polarized Load Terminals)
"A" = With Aux. Contact (SPST-NO)
"B" = With Aux. Contact (SPST-NC)
"N" = Non-Polar Load Terminals
"P" = Potted PCB

AEV250 Series DC Contactor Specification 500 Amp/900 vdc

Performance Data

| MAIN CONTACT | | LIFE | |
|---------------------------------|--|----------------------------------|---------------------------------------|
| Contact arrangement | 1 Form X (SPST-NO DM) | Resistive load life | See chart below |
| Rated Operating Voltage | 12-900VDC | Mechanical life | 200,000 cycles |
| Continuous (Carry) Current | 500 (85°C) | AUX. CONTACT | |
| Max short circuit current | 2,000A @320VDC, 1 cycle ¹ | Aux. Contact arrangement | 1 Form A, 1 Form B |
| Dielectric Withstanding Voltage | 2200Vrms (leakage <1mA) | Aux. Contact Current Max | 2A@30VDC/ 3A@125VAC |
| Insulation Resistance | Terminal to Terminal/ Terminal to coil New: Min 100 MΩ@500Vdc End of life: Min 50 MΩ@500Vdc | Aux. Contact Current Min | 100mA@8V |
| Voltage Drop (@250A) | ≤50mV | Aux. Contact Resistance Max | 0.417ohms@30VDC/ 0.150ohms @125VAC |
| ENVIRONMENTAL DATA | | OPERATE / RELEASE TIME | |
| Shock,11ms ½ sine, operating | 20G Peak | Close (includes bounce) | 25ms, Max. |
| Vibration, Sine, Peak, 20G | 80 to 2,000Hz | Release (@2000A includes arc) | 12ms, Max |
| Operating Ambient Temperature | -40 to +85°C | | |
| Altitude | <4000m | | |
| Weight | 0.95 Lb (0.43 kg) | | |
| COIL DATA | | | |
| Coil Voltage | 12 - 24VDC | 72VDC | 48 - 72VDC |
| Voltage (Max.) | 36VDC | 95VDC | 95VDC |
| Pickup voltage (Max.) | 9VDC | 48VDC | 32VDC |
| Dropout voltage (Min.) | 6VDC | 27VDC | 18VDC |
| Inrush Current (Max.) | 3.8A | 0.7A | 1.3A |
| Holding Current (Avg.) | 0.13A@12VDC / 0.07A@24VDC | 0.02A@72VDC | 0.03A@48VDC |

Note:

*1: Does not meet dielectric & IR after test.

*2: current carry is dependent on cross sectional area
area of conductor

AEV250 Series DC Contactor Specification 500 Amp/900 vdc

Electrical life

Estimated Make & Break Resistive Load Ratings for polarized type

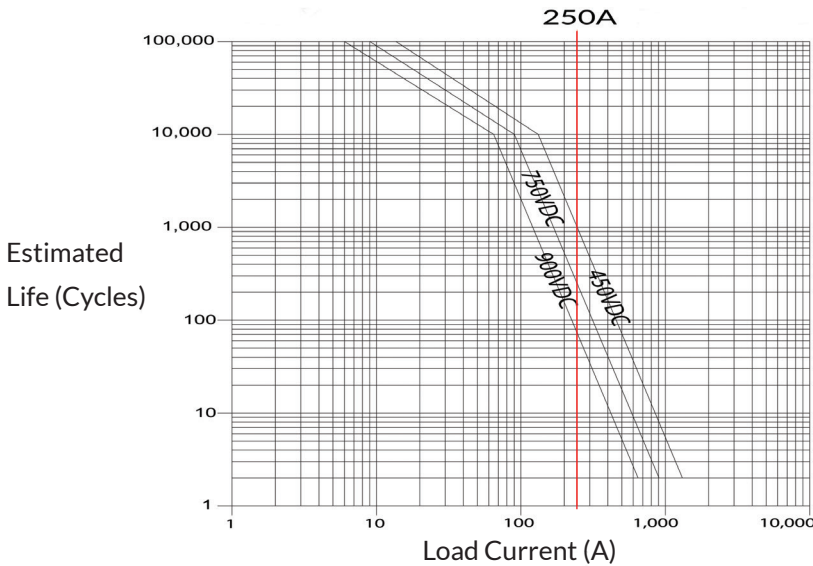

Note:

Estimates based on extrapolated data. User is encouraged to confirm performance in application.

Estimated Electrical Life:

Polarity Sensitive Type

| | | |
|--------------|------|-----|
| Voltage (V) | 450 | 650 |
| Current (A) | 250 | 250 |
| Life (Cycle) | 5000 | 500 |

Estimated Electrical Life:

Non-Polarity Sensitive Type

| | | |
|--------------|------|-----|
| Voltage (V) | 450 | 650 |
| Current (A) | 250 | 250 |
| Life (Cycle) | 2000 | 500 |

Polar type electrical Load Life Ratings for Typical EV Applications

| MAKE/BREAK LIFE CAPACITIVE & RESISTIVE LOADS AT 320VDC*1 | |
|--|---------------|
| @90% pre-charge (make only), see chart below | 50,000 cycles |
| @Min 80% pre-charge (make only), see chart below | 50 cycles |

Note:

*1: Resistive load includes L=25uH. Load @2500A, test @200uH

AEV250 Series DC Contactor Specification 500 Amp/900 vdc

AEV250 Capacitive Make Test Curves for Pre-Charged Motor Controller

Current Carry vs Time

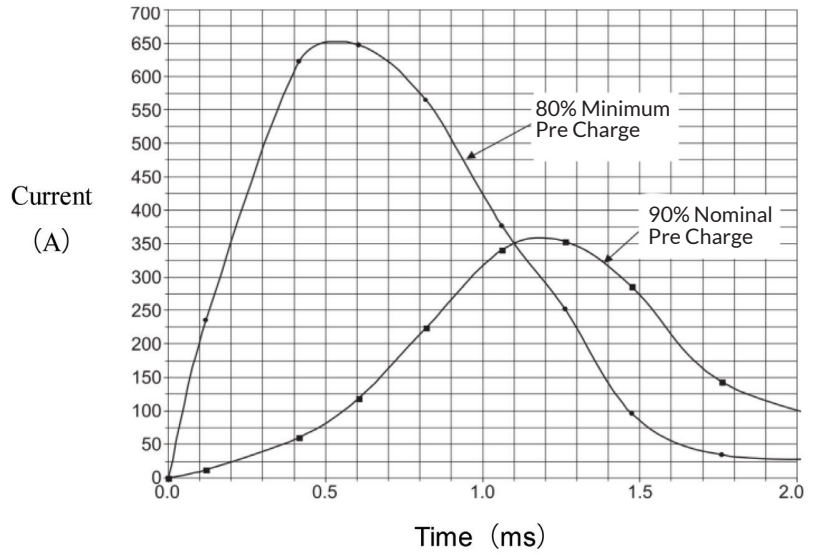
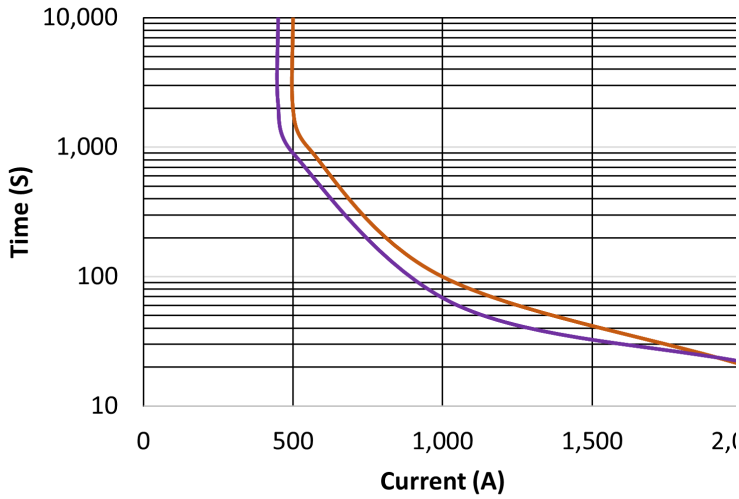

Outline Dimensions: in. (mm)

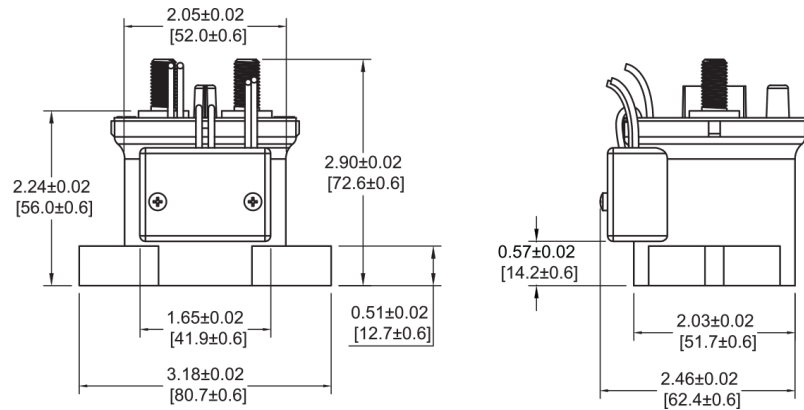
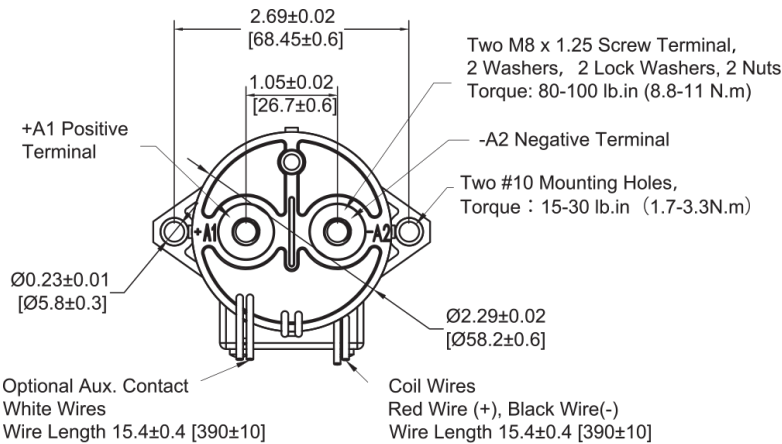

Note:

No Polarity mark on non-polarity "N" type

AEV250 Series DC Contactor Specification 500 Amp/900 vdc

Application Note:

1. Be sure to use washer to prevent screws from loosening. Tighten the screw torque range is specified as below. Exceeding the maximum torque can lead to product rupture.
 - Contact torque (M8): 80 - 100 lb.in (8.8 - 11 N.m)
 - Mounting torque: 15 - 30 lb.in (1.7 - 3.3 N.m)
2. Please refer to drawing for polarity sensitive type during connecting; No orientation for non-polar type.
3. Do not use dropped products.
4. Avoid to install the product in a strong magnetic field (Close to the transformer or magnet), or near an object with heat radiation.
5. Electrical life
Please use under load capability and life cycle so as not to cause a function failure. (Please also treat the contactor as a product with specified life and replace it when necessary). It is possible to make parts burn around the contactor once operating failure happens. So it is necessary to take layout into account to make sure power shall be cut off within 1 second.
6. Lifetime of internal gas diffusion
The contactor is sealed and filled with gas, lifetime of gas diffusion is determined by temperature in contact chamber (Ambient temperature + Temperature rising by contact energizing). Therefore environment temperature should be from -40 to +85°C.
7. Do not let particle and oil stain on the main terminal with which the load shall make a reliable contact. Or it will cause excess.