

# AGX14 Series DC Contactor Specification 350 Amp / 800 VDC



## Application

AGX14 is designed for High Current DC applications. It can meet the application requirements of DC current transmission and control for different types of photovoltaic/wind power generation systems, electric vehicles and charging stations



## Certification Information

Product complies with RoHS standard (2011/65/EU)

## Nomenclature

AGX14

B

A

B

Series code:  
"AX14"=AX14 Series

Coil Voltage:  
B=12 Vdc Internal Coil Suppression  
C=24 Vdc Internal Coil Suppression  
E=48 Vdc Internal Coil Suppression

Coil Termination  
A=Flying leads38cm(15in)  
B=Flying leads61cm(24in)  
C=Flying leads122cm(48in)  
D=Coil Termination not available with Auxiliary Contacts

Auxiliary Contact:  
Blank=None  
B=SPST, Normally Open  
C=SPST, Normally Closed

# AGX14 Series DC Contactor Specification 350 Amp / 800 VDC



## Performance Data:

Main Contact			Expected Life	
Contact Arrangement	1 Form X (SPST-NO DM)		Mechanical life	200,000 Cycles
Max. Switching Voltage	800 Vdc			
Rated Current	350 A			
Contact resistance	0.4mohms			
Max Short Circuit Current	2000A@320Vdc		AUX Contact	
Dielectric Withstanding Voltage (Initial)	Between Open Contacts	4000Vms,1min,<1mA	Aux. Contact arrangement	1 Form A
	Between Contacts to Coil	2200Vms,1min,<1mA	Aux. Contact Current Max.	2A@30Vd 3A@125Vac
Insulation Resistance (Initial)	Terminal to Terminal	New: 100M $\Omega$	Aux Contact Current Min	100mA@8V
	Terminals to Coil	End: 50M $\Omega$	Aux. Contact Resistance Max	0.417ohms@30Vd 0.150ohms@125Vac
Environmental Data			Operate Time	
Shock	Functional	20G	Operate Time	20ms
	Destructive	20G	Release Time	12ms
Operating Temperature	-55°C to +85°C			
Altitude	<4000m			
Weight	500g			

# AGX14 Series DC Contactor Specification 350 Amp / 800 VDC



## Coil Data (Cont.):

Coil Data at 25°C			
Coil P/N Designation	B	C	E
Nominal Voltage	12VDC	24VDC	48VDC
Coil Voltage (Max.)	16VDC	32VDC	64VDC
Pick-up Voltage (Max.)	8V	16V	40V
Drop-out Voltage (Min.)	0.5-4V	2-7.5V	4-15V
Pick-Up Current, Max (75 ms)	3.9A	1.6A	0.97A
Coil Current	0.23A	0.097A	0.042A
Coil Power	2.8W	2.3W	2.0W
Internal Coil Suppression			
Coil Back EMF	55V	55V	125V
Transients ,Max(13ms)	±50V	±50V	±75V
Reverse Polarity	16V	32V	64V

# AGX14 Series DC Contactor Specification 350 Amp / 800 VDC



## Performance Data

Carry Current Performance (with 85°C terminal Temperature rise):

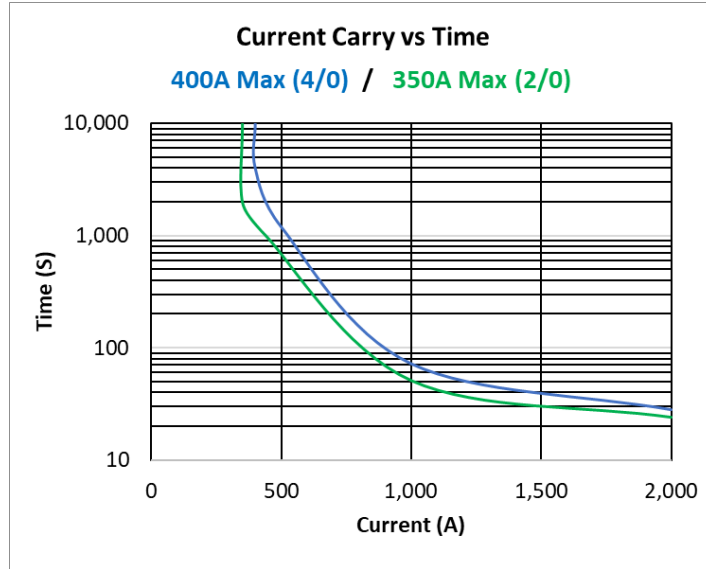

## Electrical Life

Estimated Make and Break Resistive Load Ratings

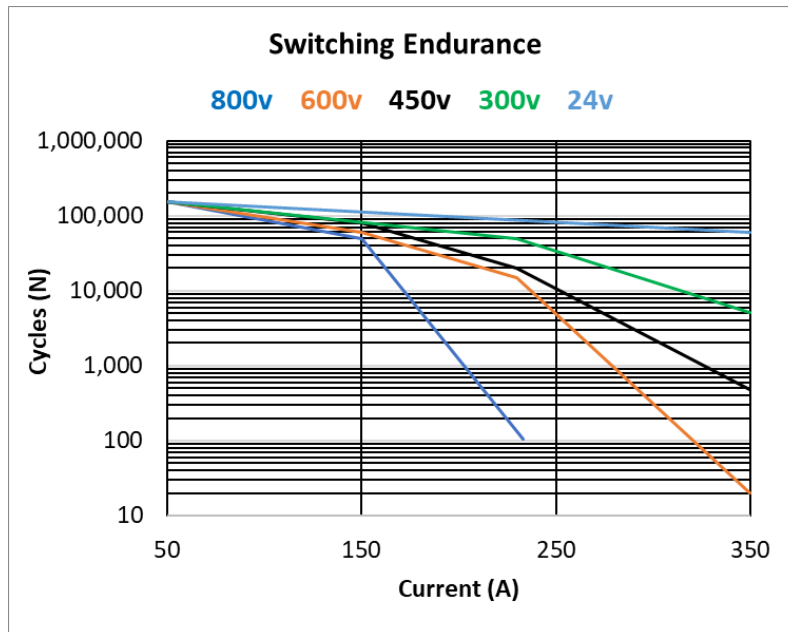

# AGX14 Series DC Contactor Specification 350 Amp / 800 VDC



## Outline Dimensions: Inches (mm)

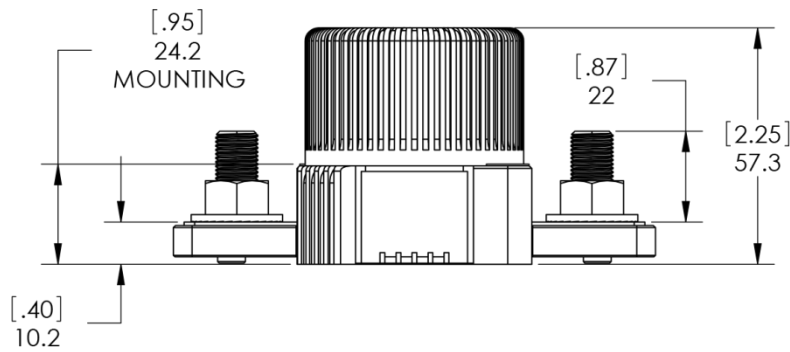
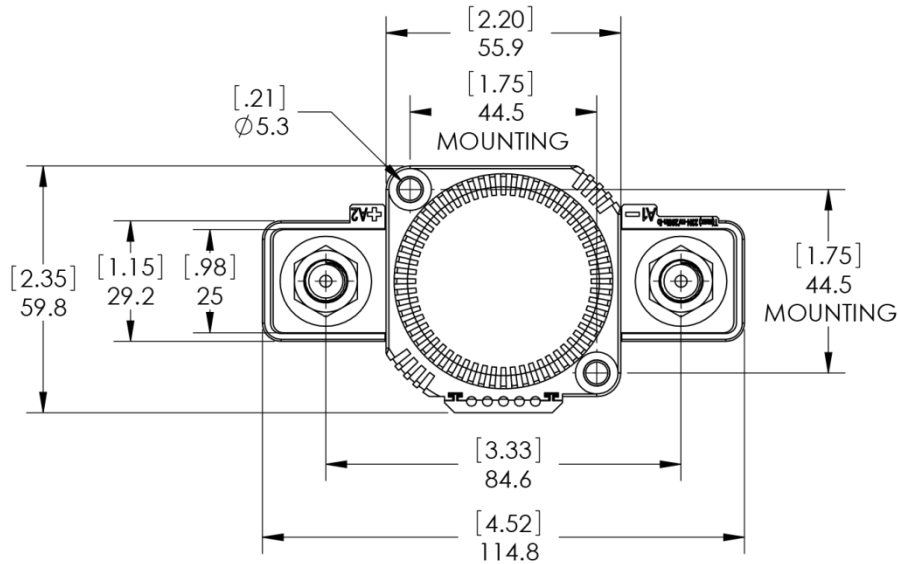

### Power Contacts

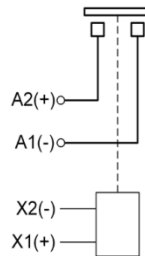

### Auxiliary contacts (optional)

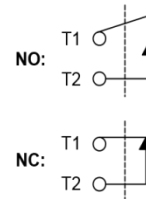

# AGX14 Series DC Contactor Specification 350 Amp / 800 VDC



## APPLICATION NOTES:

1. Contactors feature internal transorb for coil suppression. No external diodes should be added across the coil. The use of additional external coil suppression can slow the release time and invalidate the life cycle ratings, or can cause the contactor not to be able to interrupt the maximum current specified. If lower coil back EMF is required, please contact Altran for assistance.
2. Power switching lifecycles are based on current flow from A2(+) to A1(-). For best breaking performance, the contactor should be installed so that current flows from A2(+) to A1(-). There are cases where the contactor will interrupt power in the opposite direction but please contact Altran to confirm suitability. Direction of current flow is not relevant during make or when flowing on closed contacts. For bi-directional contactors, please contact Altran.
3. Applications with capacitors will require a pre-charge circuit.
4. Electrical life rating is based on resistive load with 27 $\mu$ H maximum inductance in circuit. Because your application may be different, we suggest you test the contactor in your circuit to verify life is as required.
5. End of life is defined as when the dielectric, insulation resistance or contact resistance fails the specifications listed.
6. Supply power must be greater than coil power or it will reduce performance capability.
7. Please do not allow debris and oil to the main terminals; Make sure that the main terminals are in reliable contact with the load conductor, otherwise the temperature rise of the terminal/conductor connection may be too high due to the excessive contact resistance.
8. Do not use if dropped.
9. Avoid mounting the relay in strong magnetic fields (near a transformer or magnet) or close to an object that radiates heat.
10. Is impossible to determine all the performance parameter in each specific application, therefore, customers should choose the products matching them according to their own conditions of use If in doubt, contact Altran, however, the customer will be responsible for validating that the products meet their application.
11. Altran reserves the right to make changes as needed. Customers should reconfirm the contents of the specification or ask for us to supply a new specification if necessary.